

**V. Mykhailenko, G. Mikhnenko, J. Chuniyakov,  
O. Petruchenko, V. Bachynskiy**

## **MATHEMATIC MODEL OF THE CONVERTER WITH FOURTEENZONE VOLTAGE REGULATION**

*Abstract:* The article focuses on the analysis of electromagnetic processes in the electric circuits with semiconductor switches. The mathematical model of the converter with fourteenzone regulation of output voltage has been developed to analyse electromagnetic processes in semiconductor converters with pulse-width regulation. The graphs representing electromagnetic processes in electric circuits are given.

*Keywords:* semiconductor converter, zonal voltage regulation, electromagnetic processes.

### **Introduction**

Now for research in the field of electrical engineering allows using in conversion units a high-frequency link with a significantly greater rate of switching valves [1-4]. The works [1-4] demonstrate the importance of using frequency converters (FCs) with single modulating in the structure of secondary power supply systems. This paper focuses on the structure of frequency converters for electromechanical complexes with pulse-width regulation of DC voltage when fourteenzone control is carried out. In this study, we analyse the use of the structure of semiconductor converters as a high frequency link concerning the design and analysis of converters for electromechanical complexes with pulse-width regulation of DC voltage when fourteenzone control is performed.

**The aim of the study** is to create a mathematical model of semiconductor converters with electromechanical load of output voltage.

### **Analysis of electromechanical processes**

In this paper we used the method of multiparameter modulating functions [2], which implies a preliminary representation of the algorithmic equation of the converter. The following assumptions are made: the input power network is symmetric, and its internal resistance is zero; transistors and diodes of the rectified voltage inverter are ideal switches; matching transformers in every regulating zone of output voltage have no losses, and the load of the converter has an equivalent active inductive character.

A schematic diagram of the converter is shown in Fig. 1. The symbols of the diagram are as follows: *PMAB*, *PMBC*, *PMCA* – power modulators (PM) of linear AB, BC and CA respectively, *FR* is a high-frequency rectifier, *D* is a DC motor. The set of PMs, connected to the power network in parallel and connected at the terminal in series, represents a high frequency link of the converter. Each of the PM elements has its own rectifiers and inverters loaded on matching transformers.

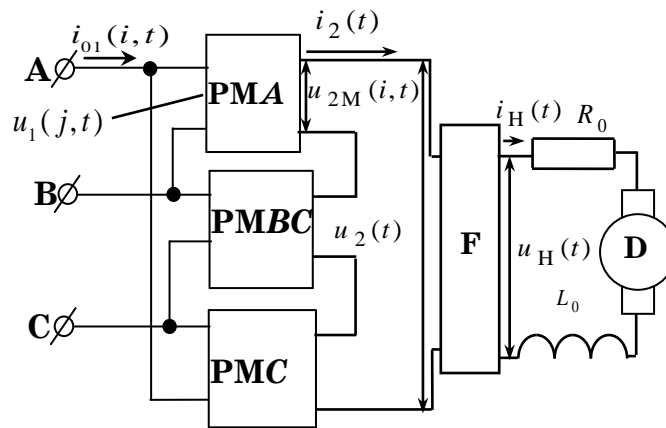

Figure 1. Schematic diagram of the converter

We can see that every PM has  $N$  rectified voltage inverters, where  $N$  is the number of inverters. Creating a mathematical model of the converter involves the development of mathematical support capable of analysing the generated energy together with the load, the energy consumed, as well as the energy which is transformed in certain sections and elements.

The research of technical and economic indications of various performance elements in tracking systems on the basis of high torque DC motors of series 2P and PV and three-phase induction motors of 4A series, which are commercial products [4], shows that for the same indications of mass and dimensions in the power range 100 W – 500 kW, it is worthwhile to use DC motors in tracking systems.

The following assumptions are made: the input power network is symmetric and its internal resistance is zero; transistors and diodes of the rectified voltage inverters are ideal switches; matching transformers in every regulating zone of output voltage have no losses.

Let us analyse electromagnetic processes in the modulating semiconductor converter with multi-zone regulation of output voltage with the load as a DC motor with sequential excitation, taking into account such features of a systemic approach to analysis [4] as integrity and influence of external and internal factors.

The voltage on the load of the semiconductor converter is calculated as:

$$u_H(t) = \frac{1}{k_T} i_{H_k}(t) \sum_{j=1}^3 \sum_{n=1}^{N=14} u_1(t) \psi_B(j,t) \psi(n,N,t) \psi_{BB}(t), \quad (1)$$

where  $u_1(j,t)$  are instantaneous values of linear voltages,  $\psi_B(j,t)$  – square-sine functions that coincide in time with the position of corresponding linear voltages,  $n = 1, 2, \dots, N=14$  – numbers of regulating zones;  $\psi(n,N,t)$  – set of equivalent modulating influences  $j$  –  $x$  inverters PM;  $\psi_{BB}(t)$  – the square-sine function that coincides in time with the voltage position  $u_2(t)$ ;  $k_T$  is a transformation coefficient.

The DC motor that supplies output current to the semiconductor converter is described by the following system of equations [4]:

$$\begin{pmatrix} i_{H_{k+1}}(t) \\ n_{k+1}(t) \end{pmatrix} = \begin{pmatrix} i_{H_k}(t) + \frac{2(c(t) - \varepsilon_{ch})}{a_1} - \frac{2\varepsilon_a}{a_1} i_{H_k}(t) - \frac{2}{a_1} n_k(t) i_{H_k}(t) - \frac{2}{a_1 a_3} i_{H_k}^3(t) \\ n_k(t) + \frac{4(c(t) - \varepsilon_{ch}) i_{H_k}(t)}{a_1 a_3} - \frac{2\varepsilon_M}{a_3} n_k(t) + \frac{2}{a_3} i_{H_k}^2(t) - \frac{2}{a_1 a_3} i_{H_k}^3(t) n_k(t) - \frac{2\varepsilon_{M0}}{a_3} \end{pmatrix}, \quad (2)$$

where  $i_{H_k}(t)$ ,  $i_{H_{k+1}}(t)$ ,  $n_k(t)$ ,  $n_{k+1}(t)$  – armature current and angular speed of rotation of the DC motor in  $k$  and  $k+1$  intervals respectively;  $\varepsilon_{ch}$ ,  $\varepsilon_a$  – relative voltage drops in the brushes and armature windings;  $\varepsilon_M$ ,  $\varepsilon_{M0}$  – relative moments of resistance on the drive shaft;

$c(t) = \frac{u_H(t)}{E}$  – relative value of voltage in the armature;  $u_H(t)$  and  $E$  – instantaneous values of output voltage of the semiconductor converter and back electromotive force, respectively;  $a_1 = \varepsilon_a + \frac{2T_{ab}}{\Delta t}$ ,  $a_3 = \varepsilon_M + \frac{2T_M}{\Delta t}$ ;  $T_{ab}$  та  $T_M$  – electromagnetic and mechanic time constants of the motor,  $\Delta t$  – time intervals when calculations are made.

System (2) is solved by adjusting initial conditions at  $t=0$  to the preliminary recording and the assumptions that there is a linear dependence of resistance moment of the motor shaft on the speed of rotation [3]. Fig. 2 shows the diagrams of currents of the DC motor armature circuits in the case of fourteenzone regulation of output voltage of semiconductor converters.

Output current is derived from the ratio:

$$i_2(t) = i_{H_k}(t) \Psi_{BB}(t). \quad (3)$$

Input currents  $i_1(n, j, t)$  are calculated as:

$$i_1(n, j, t) = \frac{i_2(t) \Psi_B(j, t) \Psi(n, N, t)}{k_T}, \quad (4)$$

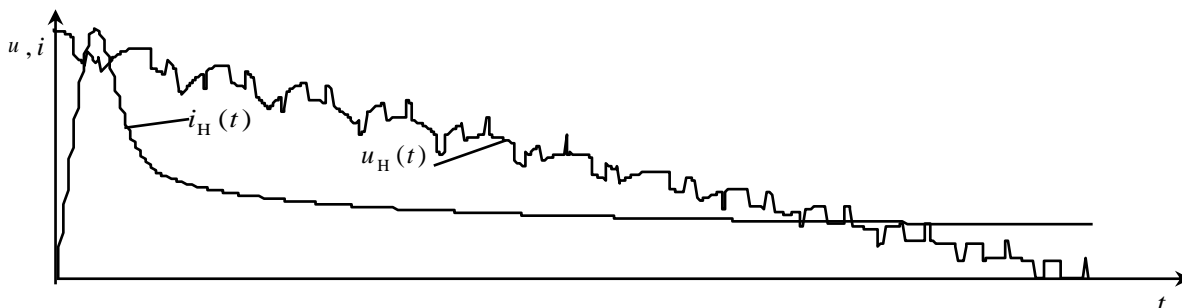

Figure 2. Diagrams of load current and voltage

Linear currents  $i_1(j, t)$  are given as:

$$i_1(j, t) = \frac{\sum_{n=1}^{N=14} i_H(t) \Psi_{B2}(j, t) \Psi_2(j, t) v_2(t)}{k_T}. \quad (5)$$

Input phase currents  $i_{02}(i, t)$  are found by means of the following ratios:

$$i_{01}(1, t) = i_1(1, t) - i_1(3, t); \quad i_{01}(2, t) = i_1(2, t) - i_1(1, t); \quad i_{01}(3, t) = i_1(3, t) - i_1(2, t). \quad (6)$$

The diagrams of input phase currents of the converter with regard to power grid voltages, built according to (6), are shown in Fig. 3.

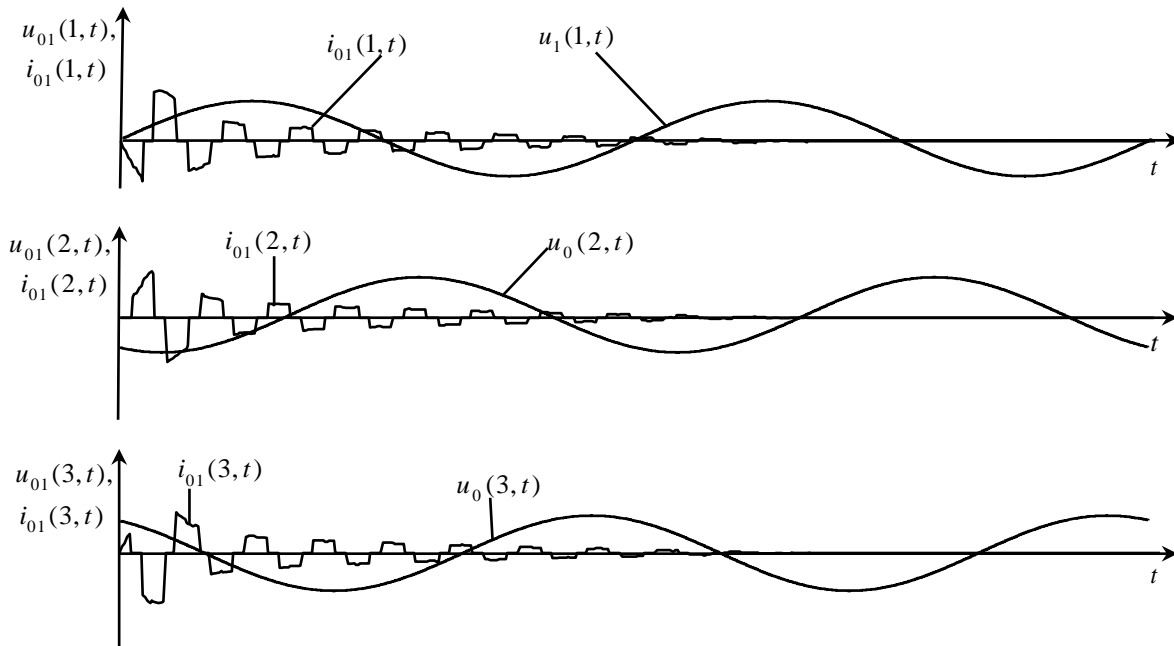

Figure 3. Diagrams of input currents of  $i$  phases of the grid with regard to phase voltages

### Conclusions

In this study we have analysed electromagnetic processes in electric circuits with semiconductor converters. We have developed the method of multiparameter functions, especially with regard to the development of a new mathematical model with multi-zone regulation of output voltage and electromechanical load and the determination of modulating functions to analyse the subsystem components of electric circuits with semiconductor switches.

Moreover, one can determine the algorithms to control the switches in circuits of power modulators of phase and linear voltages in the three-phase power supply system, which simplifies the quality improvement of sign-constant voltages in the process of formation and multi-zone regulation of output sinusoidal and sign-constant voltages. The use of multiparameter modulating functions in mathematical models of electromagnetic processes in electric circuits with semiconductor switches allows us to determine currents in inverter circuits and other semiconductor sections of each of the rectified voltage modules.

## REFERENCES

1. С. С. Розіскулов, Михайленко В. В., Перетятко Ю. В., “Регулювання тривалості перехідних процесів у напівпровідникових формувачах біполярних розрядних імпульсних струмів”, Технічна електродинаміка, Київ: ІЕД НАНУ, № 4, 2016, С. 41 – 43, doi: <https://doi.org/10.15407/techned2016.04.041>.

2. В. І.Сенько, Михайленко В. В., Юрченко М. М., Юрченко О. М., Чуняк Ю. М., “Аналіз електромагнітних процесів у колах з напівпровідниковими перетворювачами з сімнадцятизонним регулюванням вихідної напруги”, Технічна електродинаміка, Київ: ІЕД НАНУ, № 5, 2016, С. 23 – 25, doi: <https://doi.org/10.15407/techned2016.05.023>.

3. Н.І. Супруновська, Ю. В. Перетятко, С. С. Розіскудов, В. В. Михайленко, В. І. Чибеліс, В.С. Олійник, “Регулювання параметрів біполярних імпульсних струмів у навантаженні напівпровідникових електророзрядних установок із накопичувальним конденсатором”, Технічна електродинаміка, Київ: ІЕД НАНУ, № 5, 2017, С. 39–46, doi: <https://doi.org/10.15407/techned2017.05.039>.

4. Михайленко В., Майкович І., Наухацька Т., Рокицький Р., “Аналіз електромагнітних процесів у перетворювачі з двадцятизонним регулюванням вихідної напруги”, Енергетика, економіка, технології, екологія, Київ: КПІ ім. Ігоря Сікорського, № 1, 2017, С. 77 – 82, doi: <https://doi.org/10.20535/1813-5420.1.2017.102827>.