

UDC 621.3.011.74.005

**V. Mykhailenko, G. Mikhnenko, Y. Trostenko,  
V. Svyatnenko, J. Chuniyak, O. Petruchenko, V. Bachynskiy**

**A MATHEMATICAL MODEL OF THE *THREE-PHASE*  
*AC TO DC VOLTAGE CONVERTER WITH*  
*THREE-ZONE VOLTAGE CONTROL***

*Abstract:* The article deals with electromagnetic processes in electric circuits with semiconductor switches. A mathematical model of a semiconductor converter with three-zone output voltage control has been created so as to analyse electromagnetic processes in semiconductor converters with pulse-width control. The graphs showing electromagnetic processes in electric circuits are given.

*Keywords:* *electromagnetic processes, output voltage, output current.*

**Introduction**

Prospects for the development and scale of application of converters are determined by their ability to ensure the required quality of the specified parameters of electricity while achieving high energy, dynamic, technical and operational characteristics. Such capabilities have direct frequency converters, the structural, functional and fundamental organization of which allows to implement a multi-channel method of converting the parameters of electromagnetic energy with a high degree of unification of blocks and nodes.

The use of switches in the electric circuits of modern converters of electricity parameters significantly complicates the analysis of electromagnetic processes. Studies [1-4] point out the importance of using single-modulation semiconductor converters in the construction of secondary power supply systems for diagnostic complexes of electromechanical devices with various types of input energy. This paper considers the usage of semiconductor converters as a high-frequency link in a three-zone control.

**The purpose** of this study is to create a mathematical model of a semiconductor converter with a three-zone control of output voltage.

**Analysis of electromagnetic processes**

In the construction of a mathematical model of the converter, we used the method of multiparameter modulating functions [2] which provides a preliminary representation of the algorithmic equation of the converter. The following assumptions were made: the input power grid is symmetric, and its internal resistance is zero; transistors and diodes of the rectified voltage inverter are ideal switches; matching transformers in every regulating zone of output

voltage have no losses, and the load of the converter has an equivalent active-inductive character.

The complete structural diagram of the converter is shown in fig. 1, where PMA, PMB, PMC are power modulators (PM) of phase voltages A, B and C respectively; HR – high-frequency rectifier, L – load. The set of PMs, connected to the power grid in parallel and connected at the terminal in series, is the high frequency link of the converter. The PM consists of rectified voltage invertors and matching transformers (T).

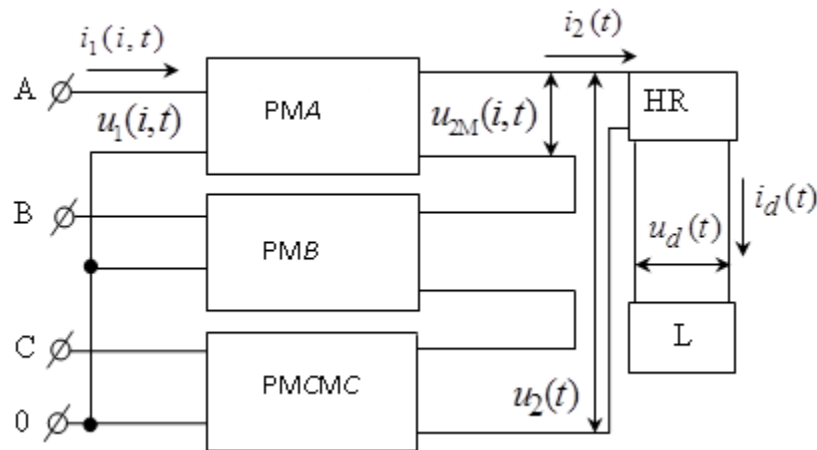

Figure 1. Structural diagram of the converter

Thus, each PM includes  $N$  (the number) of rectified voltage invertors.

This structure allows implementing a multichannel method for converting the parameters of electromagnetic power of the grid, in which the PM carries out the branchy modulation of instantaneous values of pre-rectified phase voltages  $u_1(i,t)$ , frequency  $\omega_1$ , and three-phase power supply with corresponding equivalent modulating effects  $\psi(\alpha_p,t)$  and frequency  $\omega_2$ . As a result, the modulated voltage is generated at the output of every rectified voltage invertor:

$$u_{2M}(p,i,t) = \frac{1}{k_T} u_1(i,t) \phi(i,t) \psi(\alpha_p,t) \quad , \quad (1)$$

where:  $i = 1, 2, 3$  – numbers of the phases of the power supply grid;  $k_T$  – transformation coefficient of the matching transformer;  $p = 1, 2, 3, \dots, n$  – numbers of zones of output voltage control;  $\phi(i,t)$  – rectangular sine functions coinciding in time with the positions of the respective phase voltages of the grid;  $u_1(i,t)$  – instantaneous values of the input voltage of the grid.

The functions of a rectangular sine are given as

$$\phi(i,t) = \text{sign} \left\{ \sin \left( \omega_1 t - \frac{(i-1)2\pi}{3} \right) \right\} \quad , \quad (2)$$

and instantaneous values of input voltage of the grid are represented by

$$u_1(i, t) = U_{1m} \sin\left(\omega_1 t - \frac{(i-1)2\pi}{3}\right), \quad (3)$$

$U_{1m}$  – the amplitude value of the phase voltage.

Equivalent modulating effects are given as

$$\psi(\alpha_p, t) = \frac{1}{2} \sum_2 \text{sign}[\sin(\omega_2 t \pm \alpha_p(t) - \varphi)] , \quad (4)$$

where  $\alpha_p(t)$  – the angles of control whose changes provide the pulse-width regulation of the output voltage of the converter;  $\varphi$  – initial phase of equivalent modulating effects.

The output voltage of the converter  $u_d(t)$  is calculated as follows:

$$u_d(t) = \frac{1}{k_T} \sum_{p=1}^3 \sum_{i=1}^3 u_1(i, t) \phi(i, t) \psi(\alpha_p, t) v(t) , \quad (5)$$

where  $v(t)$  – the rectangular sine function which coincides in time with the position of the output voltage;  $u_2(t)$  – the links of the high frequency converter.

$$v(t) = \text{sign}(u_2(t)) \quad (6)$$

The load current is calculated as a response of a single-loop RL-circuit to the action of voltage (7). Here is the differential equation for the output circuit of the converter:

$$D(t, y) = \frac{u_d(t)}{L} - \frac{R}{L} y_0, \quad (7)$$

where  $y_0$  is derived from the initial conditions;  $R$  i  $L$  – active resistance and inductance of the load respectively.

Solution (7) with respect to the load current is determined numerically by the matrix:

$$i_d(t) = \text{rkfixed}(y, 0, k, s, D), \quad (8)$$

where  $y$  – vector of initial conditions;  $0, k$  – time interval of the solutions;  $s$  – the number of points in the time interval of the solutions;  $D$  – vector function of differential equations.

In order to calculate the input current of the high-frequency rectifier, it is necessary to divide (7) by (6). If the conversion function has a zero level, the division for the full period of existence (8) cannot be performed. This causes the need to find the current at non-zero intervals forward of the high-frequency rectifier, with subsequent adjustments of the results of separate calculations. However, representation (6) by the function of the single amplitude allows us to determine the current  $i_2(t)$  by multiplying (8) by (6) and, thus, to simplify the process of calculations by giving the results for the full interval of existence (6) and (8). Thus, the input current of the high-frequency rectifier is equal to:

$$i_2(t) = i_d(t) v(t) . \quad (9)$$

In order to calculate the input currents of the inverters of  $i$ -phases for each  $p$ -zone of control, we accept that  $i_2(t)$  flows in the general circuit of all PMs, which is formed by the series-connected secondary windings of the matching transformers, and also take into account algorithmic equation (9) as well as the fact that (2) and (4) are the functions of a single amplitude. Thus,

$$i_1(n, i, t) = \frac{i_2(t)\Psi(\alpha_p, t)\phi(i, t)}{k_T} \quad (10)$$

The time charts of the load current in the coordinates of the output voltage of the converter built according to (5)-(8) for three-zone control are shown in Fig. 2.

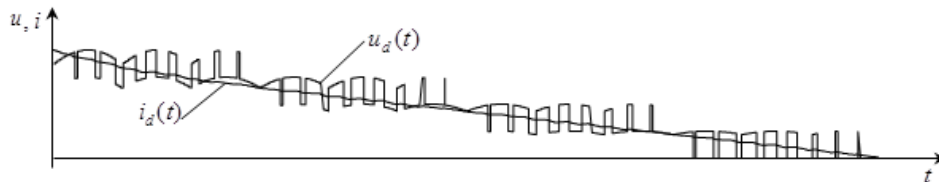

Figure 2. Time charts of the load current and voltage and input currents of inverters in the coordinates of phase voltages of the power grid

To determine the currents of  $i$ -phases of the power grid in the whole range of output voltage control, we add the input currents of the inverters of all control zones in each  $i$ -phase. Using equation (10), the currents of  $i$ -phases of the power grid are calculated as:

$$i_1(i, t) = i_1(1, i, t) + i_1(2, i, t) + i_1(3, i, t) \quad (11)$$

where  $i_1(1, i, t)$ ,  $i_1(2, i, t)$  and  $i_1(3, i, t)$  – input currents of inverters of  $i$ -phases for the first, second and third zones of control.

The time charts of the input currents of  $i$ -phases of the power grid in the phase voltage coordinates built by (11) for three-zone control are shown in Fig. 3.

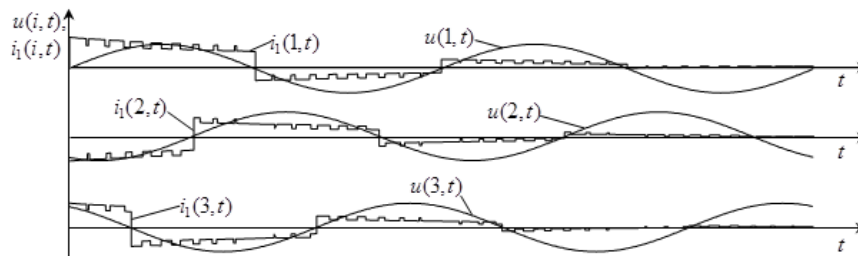

Figure 3. Time charts of the input currents of  $i$ -phases of the power grid in the coordinates of phase voltages

In order to find the amplitude of the currents through the power transistors of rectified voltage invertors, it is enough to analyse the currents  $i_{1T}(n, i, t)$  of the primary windings of the matching transformers, which are present in the circuits where currents flow through power transistors.

## Conclusions

In this study, we have analysed the electromagnetic processes in electric circuits with semiconductor switches. By means of the method of multiparameter modulating functions, the current and voltage of the load and the input currents of the converter have been calculated. We have improved this method by developing a new mathematical model with multi-zone control of output voltage and determining modulating functions to analyse subsystem components of the structure of electrical circuits with semiconductor converters.

The paper shows the effectiveness of system analysis of electromagnetic processes in semiconductor converters of modulation type according to the developed methods of system modeling, which are named as: method of multiparameter modulating functions and methods of modeling electromagnetic processes based on them. Generalized mathematical models for the analysis of converters with branched structures, mathematical support of control systems, new structures of voltage inverters and algorithms for their control in converters with variable and constant output voltages are offered. Theoretical bases of the method of many parametric functions for the analysis of semiconductor converters of the electric power concerning a three-phase power supply network are developed.

## REFERENCES

1. С. С. Розіскулов, Михайленко В. В., Перетятко Ю. В., “Регулювання тривалості перехідних процесів у напівпровідникових формувачах біполярних розрядних імпульсних струмів ”, Технічна електродинаміка, Київ: ІЕД НАНУ, № 4, 2016, С. 41 – 43, doi: <https://doi.org/10.15407/techned2016.04.041>
2. В. І.Сенько, Михайленко В. В., Юрченко М. М., Юрченко О. М., Чуняк Ю. М., “Аналіз електромагнітних процесів у колах з напівпровідниковими перетворювачами з сімнадцятизонним регулюванням вихідної напруги”, Технічна електродинаміка, Київ: ІЕД НАНУ, № 5, 2016, С. 23 – 25, doi: <https://doi.org/10.15407/techned2016.05.023>
3. Н.І. Супруновська, Ю. В. Перетятко, С. С. Розіскудов, В. В. Михайленко, В. І. Чибеліс, В.С. Олійник, “Регулювання параметрів біполярних імпульсних струмів у навантаженні напівпровідникових електророзрядних установок із накопичувальним конденсатором”, Технічна електродинаміка, Київ: ІЕД НАНУ, № 5, 2017, С. 39–46, doi: <https://doi.org/10.15407/techned2017.05.039>
4. Михайленко В., Майкович І., Наухацька Т., Рокицький Р., “Аналіз електромагнітних процесів у перетворювачі з двадцятизонним регулюванням вихідної напруги”, Енергетика, економіка, технології, екологія, Київ: КПІ ім. Ігоря Сікорського, № 1, 2017, С. 77 – 82, doi: <https://doi.org/10.20535/1813-5420.1.2017.102827>